



## THE 20<sup>TH</sup> ANNIVERSARY OF THE DEPARTMENT OF TRANSPORT TECHNOLOGICAL EQUIPMENT OF THE VILNIUS GEDIMINAS TECHNICAL UNIVERSITY

**Marijonas Bogdevičius, Bronislovas Spruogis, Henrikas Sivilevičius, Vilius Bartulis,  
Jurgis Jurevičius, Olegas Prentkovskis, Edgar Sokolovskij,  
Oleg Vladimirov, Vladimiras Suslavičius, Raimundas Junevičius, Irmantas Karalevičius,  
Aleksandr Vika, Laima Dabulevičienė**

*Dept of Transport Technological Equipment, Faculty of Transport Engineering,  
Vilnius Gediminas Technical University, Plytinės g. 27, LT-10105 Vilnius, Lithuania,  
Phone (+370 5) 2744783, Fax (+370 5) 2745060, E-mail: tti@ti.vtu.lt*

*Received 15 November 2005, accepted 2 March 2006*

The *Department of Transport Technological Equipment* was established in 1985 in the Faculty of Mechanical Technology of the Vilnius Civil Engineering Institute (now, VGTU – Vilnius Gediminas Technical University). It was called the *Department of Building and Road Machines*. The first head was Prof Dr Habil Bronislovas Spruogis (then Associate Professor).

From 1991 to 1995 being in the Faculty of Mechanics of the Vilnius Technical University (now, VGTU – Vilnius Gediminas Technical University) the department was called the *Department of Machines for Road Construction and Building Machines*.

In 1994 the Faculty of Transport Engineering was founded. In 1996 the department was renamed into the *Department of Transport Technological Equipment*. Since 1995 Prof Dr Habil Marijonas Bogdevičius is the head of the department.

Now the department academic staff includes: 3 professors, 4 associate professors, 1 lecturer, 4 assistants, 3 junior researchers, 5 doctoral students.

The *Department of Building and Road Machines* trains building and road machines specialists – Engineers of mechanics and Masters of transport engineering. Specialists of building and road machines are being trained since 1958 in the Kaunas Polytechnic Institute (now Kaunas University of Technology). First specialists graduated in 1961. Since 1969 when the Vilnius Civil Engineering Institute was founded, specialists of building and road machines were trained in the Department of Automobile Transport of the Faculty of Mechanical Technology. The Department of Building and Road Machines was established in 1985.

A great number of magistral staff of the Department of Automobile Transport was engaged in the Department of Building and Road Machines.

The Department of Transport Technological Equipment suggests:

- the *Bachelor's Degree study programs*: Transport Engineering (specialization – Transport Technological Systems Engineering) and Transport Machinery and Equipment;
- the *Master's Degree study program*: Transport Engineering (specializations – Transport Technological System Engineering, Transport Engineering Management).

The development of specialists who are given degrees by the Department of Transport Technological Equipment is presented in Fig 1.

The research area of students' final work is very wide. It includes a high scale of transport machines, technological equipment and processes.

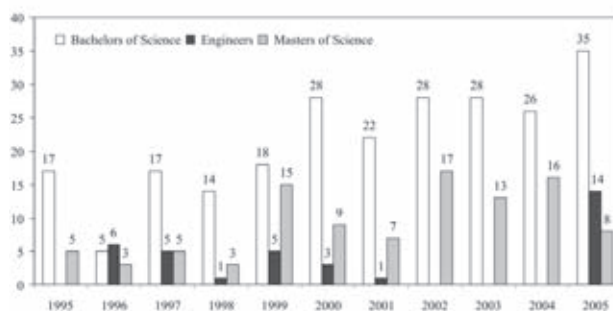

**Fig 1.** Number of specialists who are given degrees by the Department of Transport Technological Equipment

At the lectures students are acquainted with modern road machines, equipment, new technologies and new materials, new scientific achievements. Great authorities in this field are our best achievement. Some Lithuanian concerns are interested in our gratified specialists – Joint-Stock Companies “Vilniaus Kranai”, “Hansaflex”, “Kaluva”, “Kelda”, “Lithuanian Railways”, Lithuanian Road Administration, Lithuanian regional organizations of road and etc. Contracts are made with employees and partners.

Research activities are being carried out in the Department of Transport Technological Equipment. Academic staff research actual and related problems of transport, mechanical and civil engineering science.

Research areas:

- Research into processes, designing and examination of transport technological equipment;
- Research into processes, designing and examination of hydraulic, pneumatic and mechanical systems;
- Research, designing and examination of machines for roads construction, machines for mining work and pipeline transport (including forecasting and estimation of residual exploitation resource);
- Research into processes, designing and examination of the hoisting-and-transport equipment (stationary and mounted on the basis of motor vehicles);
- Designing and preparation of the documentation for the equipment intended for entertaining events;
- Definition of technical equipment requirements for roads exploitation;
- Engineering solutions of safety traffic problems (definition of dangerous sections of roads, modelling and prognostication of possible traffic accidents);
- Estimation of asphalt concrete coverings condition of roads and the offer to increase the term of their exploitation;
- Improvement of technologies and qualities of the asphalt concrete mixtures control;
- Offers and rational strategy of road asphalt concrete coverings regeneration.

Members of academic staff of the Department of Transport Technological Equipment during its history defended **6 Doctoral dissertations:**

- Marijonas Bogdevičius (1988, Moscow Automobile and Road Institute, Russia);
- Rimantas Subačius (1990, Leningrad Civil Engineering Institute, Russia);
- Vilius Bartulis (1992, Saint-Petersburg State Technical University, Russia);

- Olegas Prentkovskis (2000, Vilnius Gediminas Technical University, Lithuania);
- Rolandas Vitkūnas (2000, Vilnius Gediminas Technical University, Lithuania);
- Oleg Vladimirov (2005, Vilnius Gediminas Technical University, Lithuania)

and **4 Dr Habil dissertations:**

- Leonas Povilas Lingaitis (1989, Moscow Civil Engineering Institute, Russia);
- Bronislovas Spruogis (1997, Vilnius Gediminas Technical University, Lithuania);
- Marijonas Bogdevičius (2000, Vilnius Gediminas Technical University, Lithuania);
- Henrikas Sivilevičius (2003, Vilnius Gediminas Technical University, Lithuania).

The development of scientific work during last 6 years is presented in Fig 2–4.

Academic staff of the Department has created more than **200 researches** which are used in concrete

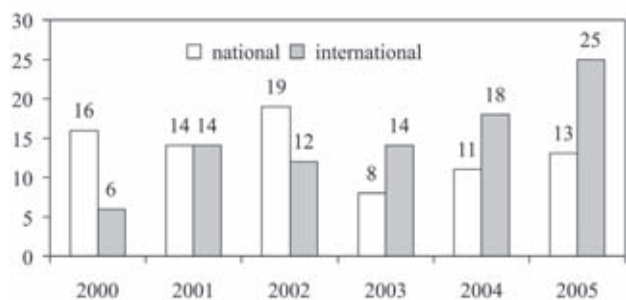

Fig 2. Reports made in conferences



Fig 3. Scientific publications in journals and proceedings

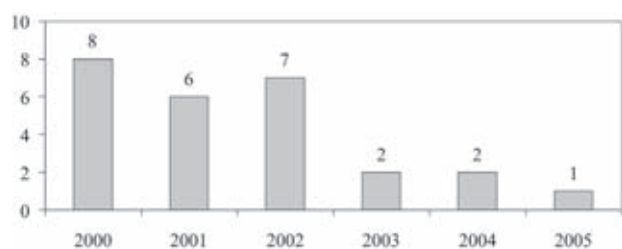
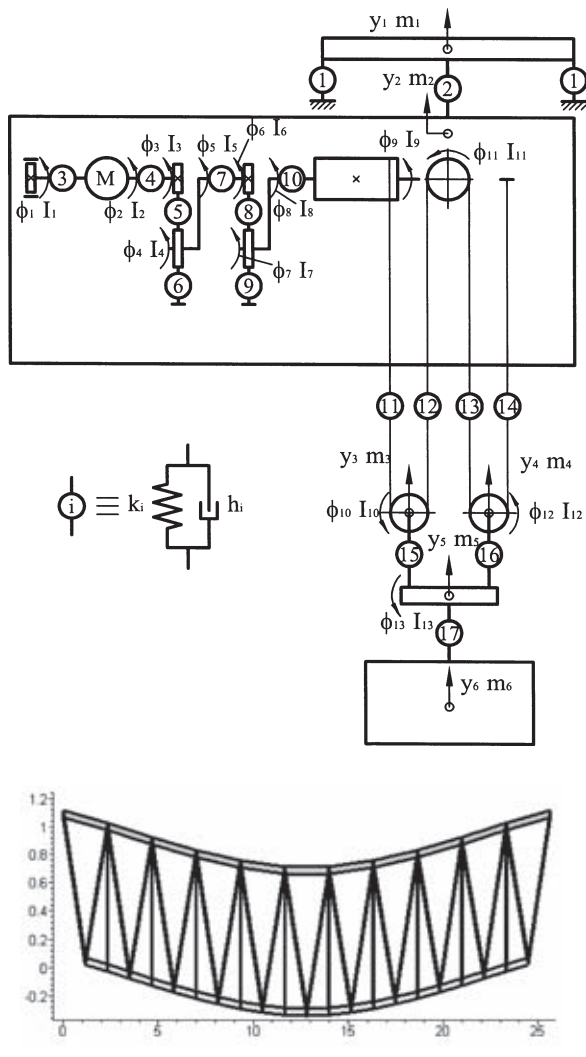

Fig 4. Number of scientific researches made by contract

constructions, defended by authors' inventions and patents. There are **6 patents** of the Republic of Lithuania, **3 patents** have been patented in the USA, the United Kingdom and Germany. The samples of construction produced on the grounds of inventions have been demonstrated in world exhibitions in Berlin, Brno, Budapest, Hague, Leipzig, Moscow, Sofia and Zagreb. They are awarded with diplomas.

**7 standards** of the Republic of Lithuania and **4 instructions** have been prepared for terms and definitions of road mineral materials and automobile roads asphalt concrete and their mixtures, for technique of experiment likewise for range of selecting and regeneration of technologies and equipment of asphalt concrete composition.

In Figs 5–19 scientific problems which are worked out by the scientists of the Department of Transport Technological Equipment are visually presented.



**Fig 5.** Research into the dynamics of overhead crane (M. Bogdevičius, A. Vika) [1]

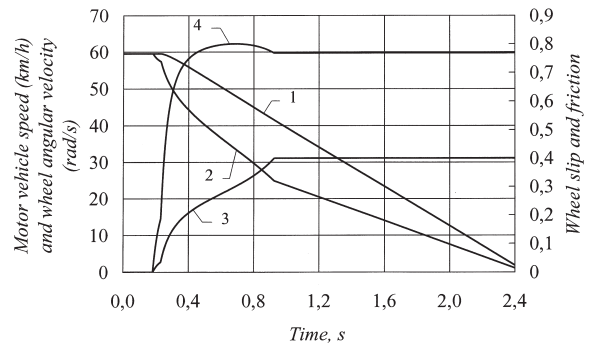
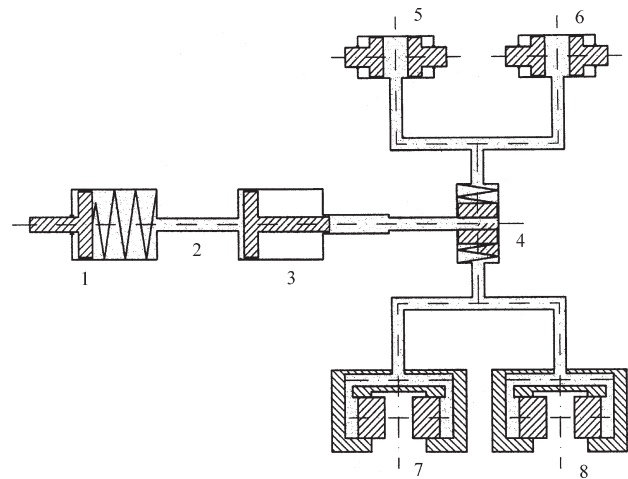

**Fig 6.** Research into the dynamic processes of a motor vehicle hydraulic brake system (O. Vladimirov, M. Bogdevičius) [2, 6]

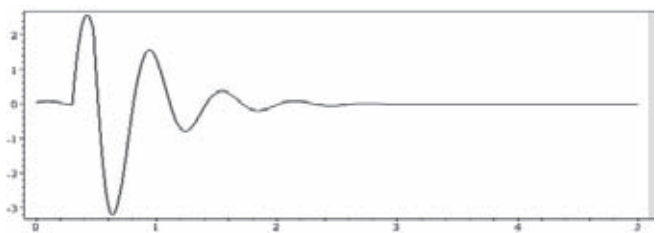

**Fig 7.** Research into dynamic processes of a motor vehicle retrofitted suspension (R. Junevičius, M. Bogdevičius) [3]

I d

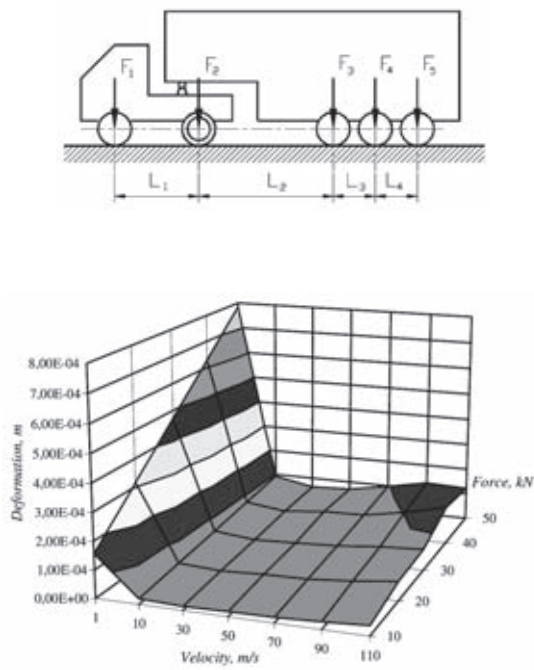

Fig 8. Interaction between a motor vehicle wheel and road surface (M. Bogdevičius) [4]

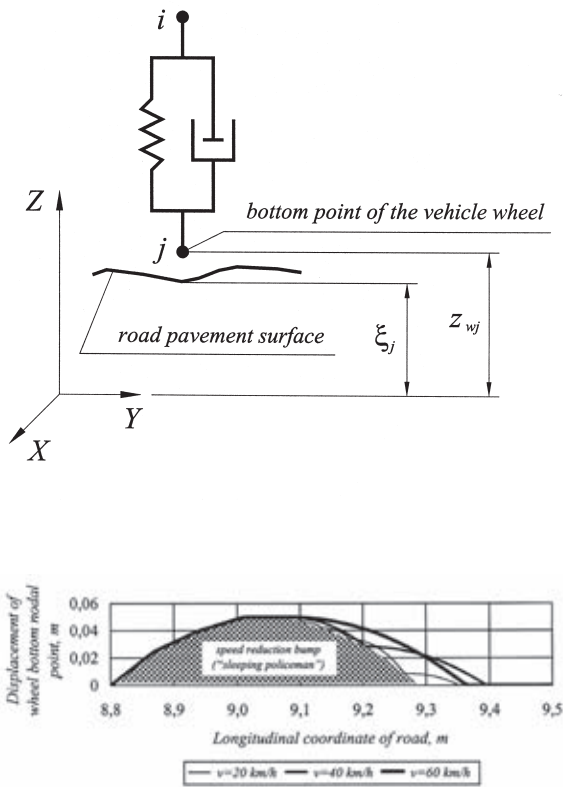

Fig 9. Motor vehicle movement on uneven road surface (O. Prentkovskis) [5]

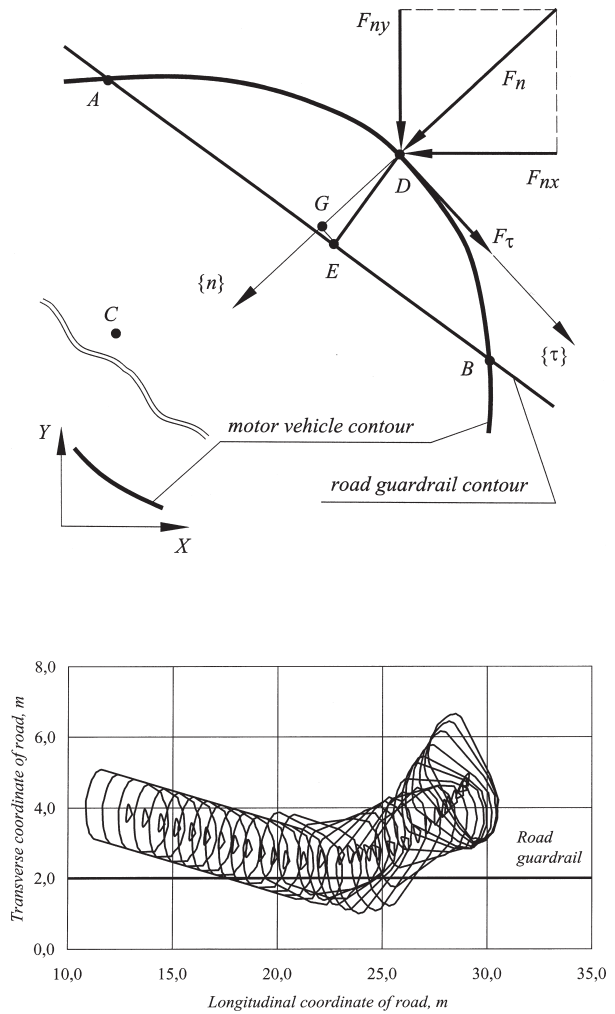

Fig 10. Interaction between a motor vehicle and road guardrails (O. Prentkovskis, M. Bogdevičius) [6]

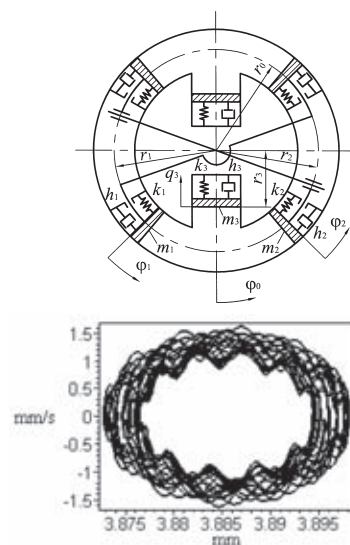
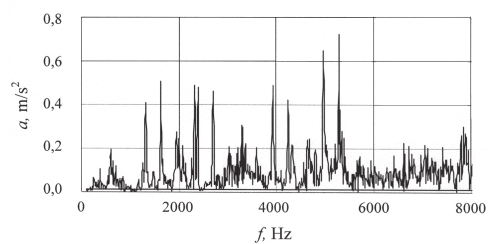
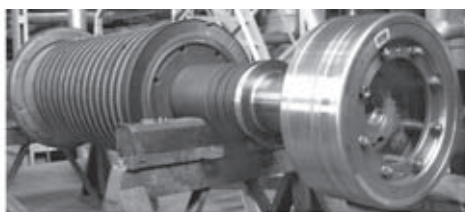
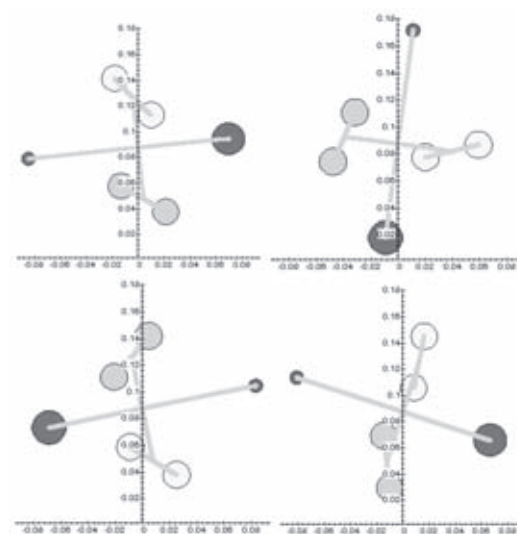
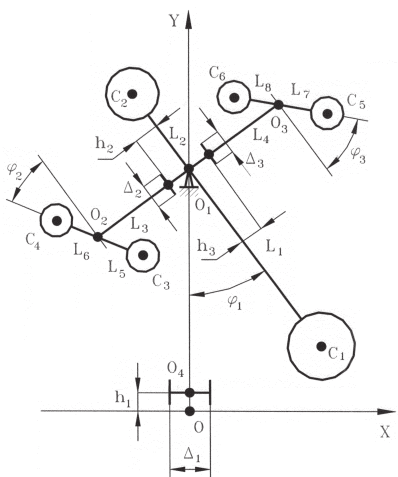

Fig 11. Research into dynamics of rotating systems (original couplings) elements (B. Spruogis, J. Jurevičius, M. Bogdevičius) [7, 8]



**Fig 12.** Designing and technical diagnosing of rotating systems (M. Bogdevičius) [9]



**Fig 13.** Research into a chaotically movement of a mechanical system with constant elements (M. Bogdevičius) [10]

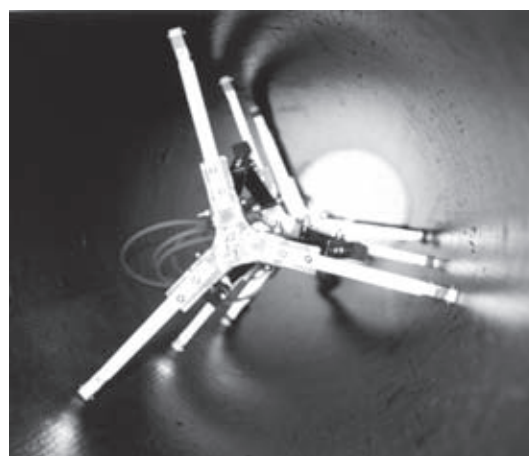

**Fig 14.** Original pipeline robots and research into their dynamics (A. Matuliauskas, V. Mištinas, B. Spruogis, M. Bogdevičius) [11]

If

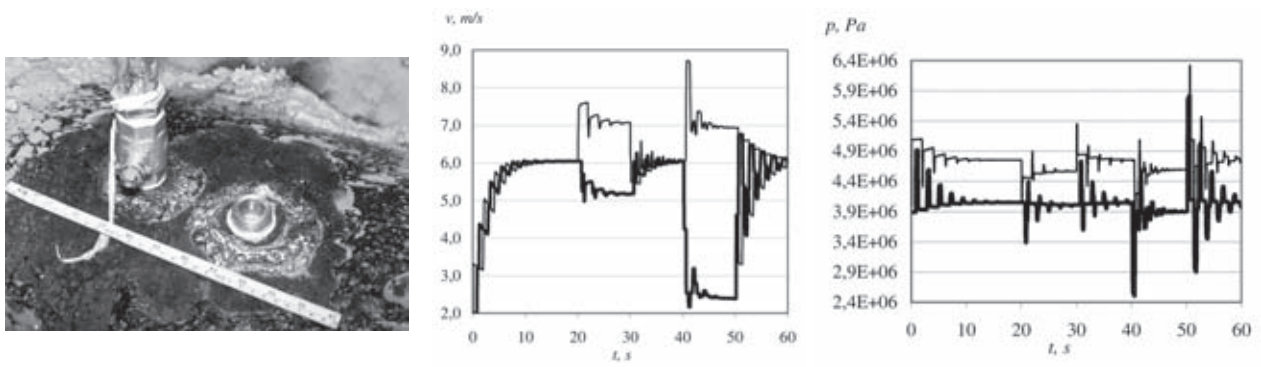

Fig 15. Method of setting oil pipelines at the moment of their unsanctioned linking (I. Bajoraitytė, M. Bogdevičius) [12]

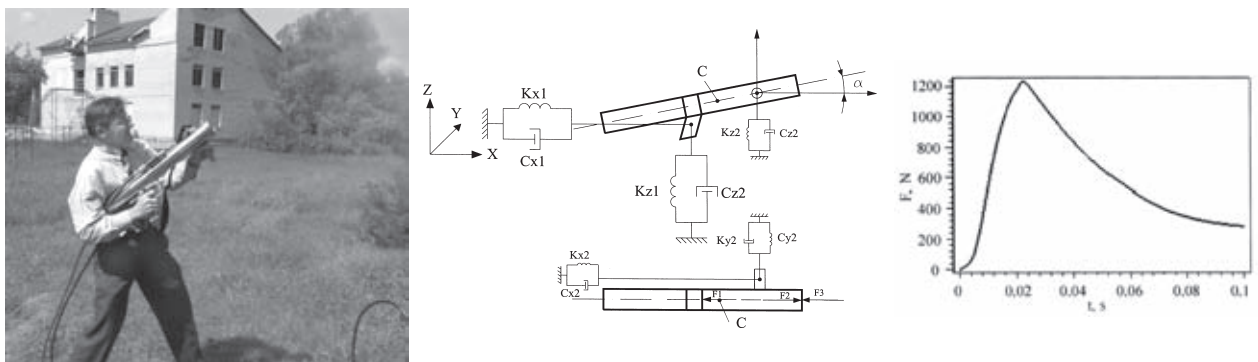

Fig 16. Original automatic hydraulic and pneumatic impulse working fighting a fire means and research into its dynamic processes (V. Suslavičius, M. Bogdevičius) [13]

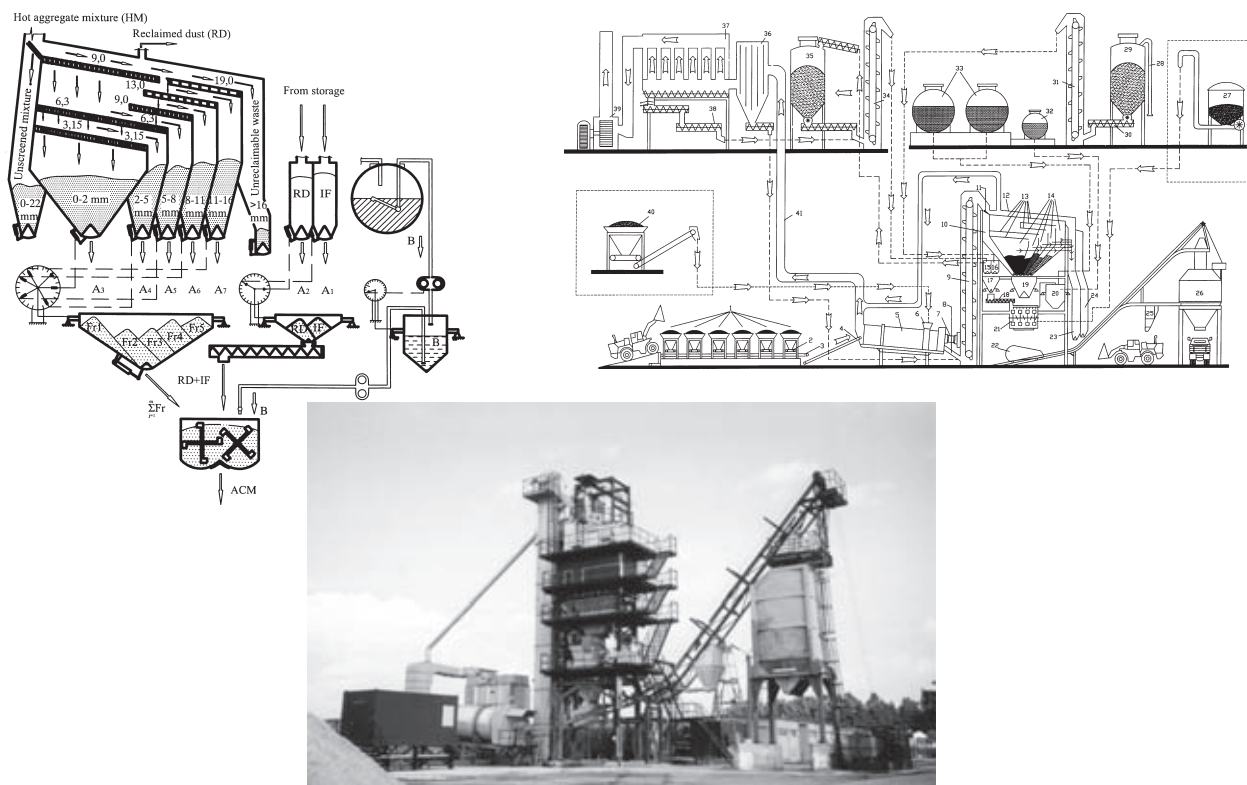

Fig 17. Methods of asphalt concrete mixtures quality increase at the moment of their making, methods of mixers technological precision increase, reduction of segregation and dosing errors in asphalt concrete mixers (H. Sivilevičius, R. Vitkūnas, I. Karalevičius) [14]

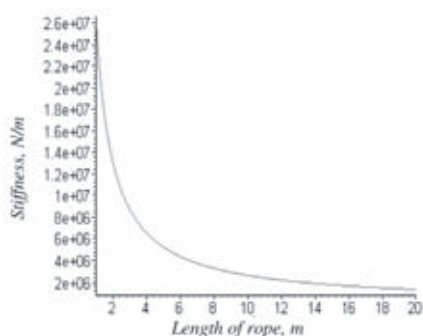
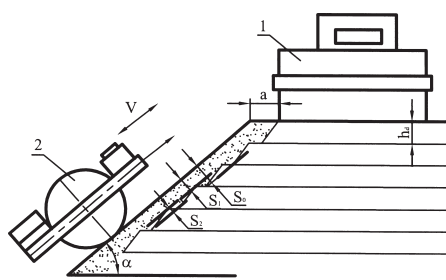

Fig 18. Equipment for soil compaction and research into dynamic processes (V. Bartulis) [15]

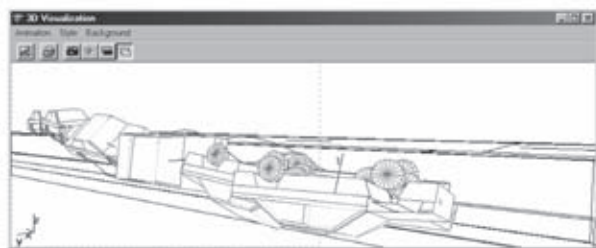
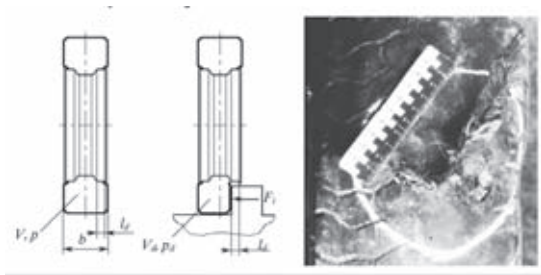

Fig 19. Investigation of the interaction of a motor vehicle wheel with a road and its elements in the context of examination of traffic accidents (E. Sokolovskij) [16]

Academic staff of the Department of Transport Technological Equipment keeps in touch relations with partners from Lithuania and international relations with partners from Belarus, Estonia, France, Germany, Latvia, Moldova, Poland, Russia, Slovakia, Sweden, Ukraine etc.

The Department of Transport Technological Equipment is new and very happy that scientists of the department are able to solve engineering problems of the Lithuanian transport system.

Information about the Department of Transport Technological Equipment of Vilnius Gediminas Technical University can be found on the website [www.ttik.ti.vtu.lt](http://www.ttik.ti.vtu.lt) in Lithuanian and English.

## References

1. Bogdevičius, M.; Vika, A. Investigation of the dynamics of an overhead crane lifting process in a vertical plane. *Transport*, Vol 20, No 5, Vilnius: Technika, 2005, p. 176–180.
2. Vladimirov, O. Research of braking process of transport vehicle with hydraulic brake system parameters. Doctoral dissertation (Lengvojo automobilio su hidrauline stabdžių sistema stabdymo proceso parametrų tyrimas. Daktaro disertacija). Vilnius: VGTU, 2005. 103 p. (in Lithuanian).
3. Bogdevičius, M.; Junevičius, R. Dynamic processes of the retrofitted rear suspension of the vehicle. *Transport*, Vol 19, No 6, Vilnius: Technika, 2004, p. 262–268.
4. Bogdevičius, M.; Prentkovskis, O.; Vitkūnas, R.; Dabulevičienė, L. Research of parameters of interaction of a wheel of the vehicle with a road covering: The report of scientific work (Transporto priemonės ir kelio dangos sąveikos parametrų tyrimas: VGTU TIF Mokslo darbo ataskaita). Vilnius: VGTU, 1997. 76 p. (in Lithuanian).
5. Prentkovskis, O.; Bogdevičius, M. Definition of a trajectory of the vehicle movement, taking into account interaction of its wheel and road surface. *Transport and telecommunication*, 2004, Vol 5, No 1, Riga: Transport and Telecommunication, p. 91–102.
6. Bogdevičius, M.; Prentkovskis, O.; Vladimirov, O. Engineering solutions of traffic safety problems of road transport. *Transport*, Vol 19, No 1, Vilnius: Technika, 2004, p. 43–50.
7. Bogdevičius, M.; Spruogis, B.; Turla, V. A dynamic model of a rotor system consisting of a flexible link with misaligned shafts. *Strojnicki Vestnik: Journal of Mechanical Engineering*, Vol 50, No 12, Ljubljana, 2004, p. 598–635.
8. Ragulskis, K.; Spruogis, B.; Ragulskis, M. Transformation of rotational Motion by inertia couplings. Monograph. Vilnius: Technika, 1999. 236 p.
9. Barzdaitis, V.; Jonušas R.; Bogdevičius, M.; Didžiokas, R. Dynamics of turbine rotating system with toothed wheel coupling. In: *ISCORMA-3: The Third Interna-*

- tional Symposium on Stability Control of Rotating Machinery, Cleveland, Ohio, USA, 19–23 September 2005: Proceedings. Minden, 2005, p. 320–329.
10. Aladjev, V.; Bogdevičius, M. Maple 6: solution of mathematical, statistical and engineering (Physical Problems (Maple 6: Решение математических, статистических и инженерно-физических задач). Moscow: Laboratory of Basic Knowledges, 2001. 824 p. (in Russian).
  11. Bogdevičius, M.; Matuliauskas, A.; Mištinis, V.; Spruogis, B.; Suslavičius, V. Dynamics of pneumatic and hydraulic transport technological equipment. *Transport*, Vol 19, No 1, Vilnius: Technika, 2004, p. 37–42.
  12. Bajoraitytė, I.; Bogdevičius, M. Dynamic processes in the oil pipelines. Part II. The leak identification by numerical methods. *Transport*, Vol 18, No 1, Vilnius: Technika, 2003, p. 49–55.
  13. Bogdevičius, M.; Suslavičius, V. Investigation of hydrodynamic processes of the extinguishing device. *Transport*, Vol 20, No 6, Vilnius: Technika, 2005, p. 219–224.
  14. Sivilevičius, H. The analysis of the new asphalt concrete mixing plant batchers and their smart control systems. In: The 6<sup>th</sup> International Conference Environmental Engineering: Selected Papers. May 26-27, 2005 Vilnius, Lithuania. Vol 2. Vilnius: Technika, 2005, p. 775–782.
  15. Bartulis, V. The effect of variable rigidity of haulage rope on the vibration rate and reliability of “Trailed vibration roller – haulage rope” system. *Transport and telecommunication*. Vol 5, No 1, Riga: Transport and Telecommunication Institute, 2004, p. 201–204.
  16. Sokolovskij, E. Investigation of interaction of the wheel with the road and its elements in the context of examination of traffic accidents. Doctoral Dissertation (Rato sąveikos su keliu ir jo elementais tyrimai eismo įvykių ekspertizės kontekste. Daktaro disertacija). Vilnius: VGTU, 2004. 147 p. (in Lithuanian).