



## EXPERIMENTAL ANALYSIS ON FLEXURAL BEHAVIOUR OF CONCRETE BEAMS WITH GFRP REINFORCEMENT

Edgaras Atutis<sup>a</sup>, Juozas Valivonis<sup>a</sup>, Mantas Atutis<sup>b</sup>

<sup>a</sup>Vilnius Gediminas Technical University, Saulėtekio al. 11, LT-10223 Vilnius, Lithuania

<sup>b</sup>Visaginas Nuclear Power Plant Project, Žvejų g. 14, LT-09310 Vilnius, Lithuania

Received 27 March 2013; accepted 31 May 2013

**Abstract.** The current economic pressures on utilities to extend a service life of structural concrete mean that concrete structures may have to perform safety functions for a time period significantly greater than their initial design life. However, the structural design and construction requirements for concrete structures with non-metallic reinforcement are very unique and not complete. This paper aims to provide experimental investigations of concrete beams reinforced with GFRP (glass fibre reinforced polymers) based on flexural strength. Both reinforced and prestressed concrete beams have been tested. Together with the strength characteristics, the effect of pre-stress on deflection and cracking distribution has been mainly governed by the stress–strain laws of reinforced concrete. The work is resulted in design code equations for the prediction of the ultimate flexural strength. The influence of the effect of prestressing on the deflection and cracking was analysed.

**Keywords:** glass fibre reinforced polymer, pre-stress, bearing capacity, experimental investigation.

**Reference** to this paper should be made as follows: Atutis, E.; Valivonis, J.; Atutis, M. 2013. Experimental analysis on flexural behaviour of concrete beams with GFRP reinforcement, *Engineering Structures and Technologies* 5(2): 76–81. <http://dx.doi.org/10.3846/2029882X.2013.814311>

### Introduction

Concrete structures with conventional reinforcement are susceptible to ageing by various processes depending on the environment and service conditions. The effects of these processes may accumulate within traditional concrete structures over time to cause failure under design conditions, or lead to repair. In recent years, experimental work with non-metallic reinforcement is being widely used to explain full-scale structural integrity of alternative composite material and develop design expressions (Gribniak *et al.* 2013; Atutis 2011, 2010; Daugevičius *et al.* 2013, 2012; Daugevičius 2010; Skuturna 2009; Borosnyoi 2002; Burke, Dolan 2002; Maruyama *et al.* 1989) In comparison, GFRP reinforcement is more cost-effective than other structural composites and it leads to a wider develop-

ment of these composites (Bank 2006). Moreover, due to corrosion resistance, high strength, light weight, and workability, glass fibre reinforced polymer materials are well suited for the newly built or rehabilitated civil engineering concrete structures such as bridges, tunnels and viaducts, marine embankments and hydropower dams or heritage buildings. However, it was observed, that long-term loading significantly reduces the tensile strength of GFRP. Due to possibility to sustain high temperatures, sudden temperature spikes, steam and gamma radiation, a number of industrial and specialised concrete structures – such as nuclear power plants – were built using non-metallic reinforcement (Demers *et al.* 2003).

Previous experiments on prestressed concrete beams with aramid fibre reinforced polymer (AFRP)

Corresponding author:

M. Atutis E-mail: [mantas.atutis@vae.lt](mailto:mantas.atutis@vae.lt)

Copyright © 2013 Vilnius Gediminas Technical University (VGTU) Press  
<http://www.tandfonline.com/TESN>



Taylor & Francis  
Taylor & Francis Group

concluded that contrary to rupture load, initial prestressing has a significant influence on crack opening force value (Kim *et al.* 2010). However, a lower modulus of elasticity of non-metallic reinforcement significantly increases midspan deflection of tested flexural members.

### 1. Materials, specimens, and test method

The test was performed in the laboratory of Civil Engineering of Vilnius Gediminas Technical University (VGTU) in 2013. Four beams were prepared for experimental investigation. Geometry and structural characteristics are provided in Table 1.

Table 1. Properties of specimens

Beam No.	$h$ (m)	$b$ (m)	$a$ (m)	$l$ (m)	Reinforcement ratio $\rho$ (%)
S-1	0.303	0.146	0.05	2.0	0.665
S-2	0.302	0.150	0.05	2.0	0.650
SI-1	0.303	0.148	0.05	2.0	0.656
SI-2	0.301	0.149	0.05	2.0	0.657

Concrete mechanical properties for specimens are provided in Table 3. Specimens were tested after 28 days under normal conditions according to LST EN 206-1.

Table 2. Mechanical properties of GFRP rebars

Tensile strength $f_{fu}$ MPa	Modulus of elasticity $E_f$ GPa	Ultimate strain $\epsilon_{fu}$
1418.2	60.2	0.0236

Table 3. Mechanical properties of concrete

Mean concrete cube compressive strength $f_{cm,cube}$ MPa	Mean concrete cylinder compressive strength $f_{cm}$ MPa	Mean axial tensile strength $f_{ctm}$ MPa	Mean secant modulus of elasticity of concrete $E_{cm}$ GPa
36.3	31.5	3.34	26.5

Beams were reinforced with steel rebars and 12 mm diameter *SchockComBAR* glass fibre reinforced polymer (GFRP) rebars. Mechanical properties of reinforcement were estimated by experiment and are presented in Table 2.

The stress of 27% of the ultimate tensile strength of the GFRP rebars at the jacking were estimated. Calculated concrete stress of transfer at extreme top fiber were 2.1 MPa and at the extreme bottom fiber – 6.2 MPa.

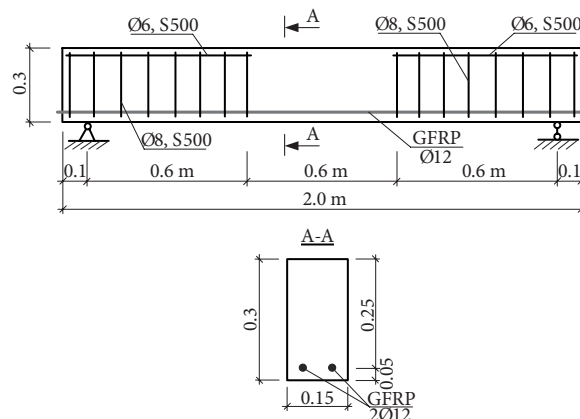

Fig. 1. Scheme for reinforcement of beams S-1, S-2, SI-1 and SI-2

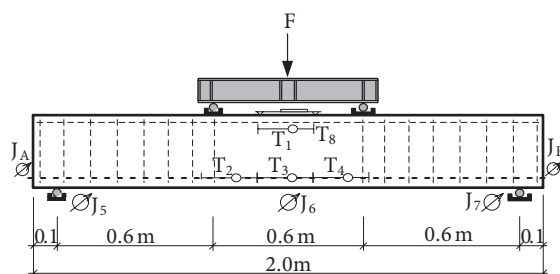

Fig. 2. Structural system and arrangement of measurements

Beams S-1 and S-2 were reinforced with 2Ø12 mm longitudinal GFRP and tangential Ø 8 mm steel rebars. Beams SI-1 and SI-2 were prestressed with 2Ø12 mm longitudinal GFRP rebars. Figure 1 shows reinforcement scheme of tested beams.

Beams (S-1, S-2, SI-1 and SI-2) were tested under a four-point loading scheme (Fig. 3). The test was performed with small increments (5 kN) and paused for short periods to take readings of gauges and to measure crack distribution, then increasing load value by 10 kN till beam failure occurred. Relative deformations of beams, midspan deflection and support deviations were measured by inductive sensors. Measurement base of all inductive sensors was 200 mm. At the end of tensile zone rebars mechanical micrometers were installed for measurement of rebar slip against concrete.

### 2. Calculation of flexural strength

The basis for the flexural strength design methodology of concrete member with non-metallic reinforcement is the balanced reinforcement ratio  $\rho$ . The balanced ratio  $\rho_b$  is the reinforcement ratio, at which concrete compression

and rebar rupture failure occurs. Any reinforcement ratio above this value leads to a primary concrete compression failure, while any reinforcement ratio below the balanced ratio indicates a rebar rupture failure. Beams with a reinforcement ratio  $\rho$  greater than  $\rho_b$  fail due to concrete compression and rebar doesn't succeed the limit strain.

According to U.S. Code (ACI 440.4R), flexural strength of over-reinforced beams can be estimated using the equation:

$$M_n = 0,85 f'_c \beta_1 b k_u d^2 \left( 1 - \frac{\beta_1 k_u}{2} \right), \quad (1)$$

where  $\beta_1$  is a factor defined as the ratio of the equivalent rectangular stress block depth to the distance from the extreme compression fibre to the neutral axis depth,  $b$  – width of the cross section,  $d$  – distance from centroid of outermost reinforcement to extreme compression fibre,  $f'_c$  – specified compressive strength of concrete,  $k_u$  – relative height of the compression zone.

According to European design recommendations (CEB-FIP 2007), flexural strength can be estimated using the equation:

$$M_n = \rho \cdot b \cdot d \cdot f_{pu} \left( d - \frac{x}{2} \right), \quad (2)$$

where  $f_{pu}$  is the tensile strength of reinforcement,  $x$  – the height of the compression zone,  $\rho$  – reinforcement ratio.

According to the Canadian Design Code (CAN/CSA) (Canadian Standards Association 2004), flexural strength can be calculated as follows:

$$M_n = C \cdot \left( d - \frac{\beta_1 \cdot x}{2} \right), \quad (3)$$

where  $C$  – equivalent force of the compression zone, which can be also estimated as follows :

$$C = \alpha_1 \cdot \varphi_c \cdot f'_c \cdot b \cdot \beta_1 \cdot x, \quad (4)$$

where  $\alpha_1$  is correction coefficient of concrete compression zone stress block,  $b$  – width of cross section,  $\varphi_c$  – correction coefficient of concrete compressive strength.

### 3. Analysis of results

Flexural strengths of concrete beams were estimated using different design code techniques. The results are shown in Table 4. Together with theoretical analysis results, experimental data is provided for comparison in Figure 3.

For comparison, the disagreement between theoretical and experimental results is 5.89% when flexural strength is estimated using *fib* recommendations. The most significant disagreement between theoretical and experimental results was found using U.S. Design

Code, which amounted to 20.57%; while 19.18% was estimated using the theoretical approach from the Canadian Design Code. Table 4 and Figure 3 show the comparison between theoretical and experimental flexural strengths.

Table 4. A comparison of experimental and theoretical flexural strength

Beam No.	$M_{exp}$ (kNm)	$M_{exp}/M_{ACI\ 440}$	$M_{exp}/M_{fib\ 40}$	$M_{exp}/M_{CAN}$
SI-1	57.27	1.254	1.076	1.251
SI-2	56.79	1.259	1.059	1.234
S-1	39.93	1.087	1.015	1.128
S-2	38.88	1.080	1.005	1.084

As experimental work shows, varying load value, the deflection of beams S-1, S-2, SI-1 and SI-2 tends to expose the linear increment. The stiffness of tested beams was also significantly reduced when the cracking load was reached. Cracking opening moment and maximum bending moment ratio of prestressed GFRP beams was  $M_{cr,exp}/M_{u,exp} = 0.41$  and for non-prestressed beams – 0.22. It shows that stiffness of prestressed concrete beams with GFRP is approx. 1.86 times greater. This difference results from compressive stress caused by prestressing in the tension zone of the beams.

Figure 4 shows the relationship between stresses of GFRP rebars and the actual bending moment. Under the limit flexural resistance, the stresses of GFRP rebars reached 80% of tensile strength of beam SI-1 and 60% of the beam SI-2. Therefore, the high tensile strength of GFRP rebars might be used more effectively when concrete beams are prestressed.

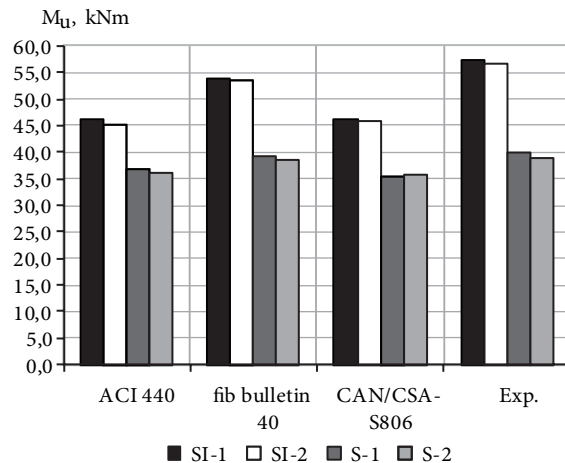

Fig. 3. A comparison of experimental and theoretical flexural strength

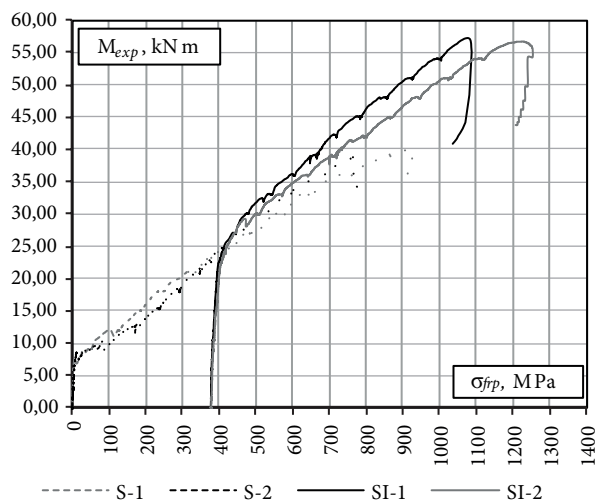

Fig. 4 Relationship between stresses of GFRP and actual bending moment

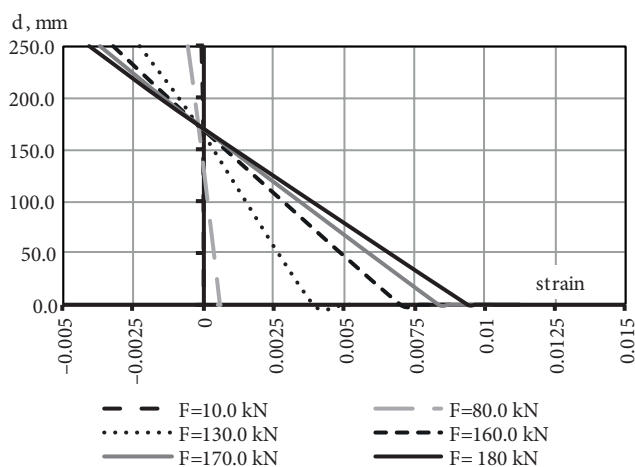

Fig. 5. Distribution of strain in the cross section of the beam SI-2

Figure 5 shows the distribution of deformations due to increases of the actual load on the beam SI-2. The neutral axis of the beam cross section is near the centre of gravity, when the load is not significant. Once load is increasing, the position of the neutral axis changes and becomes close to extreme compression fibre, because of the decrease in the height of the concrete compression zone. Therefore, concrete beams S-1, S-2, SI-1 and SI-2 failed in the compression zone.

Failure modes of reinforced and prestressed concrete beams with GFRP and distribution of cracks are provided in Figures 6 and 7. According to different design codes, over-reinforced beam failure mode starts due to the reached compressive concrete limit strain.

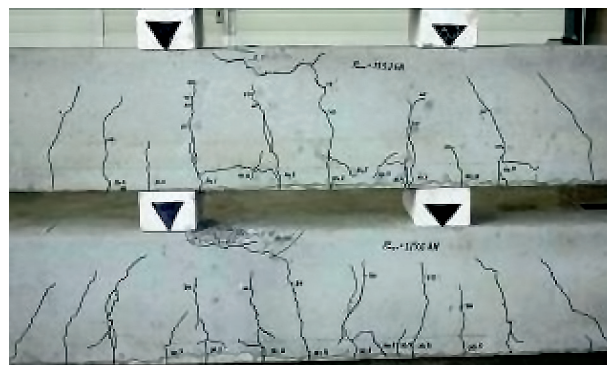

Fig. 6. Failure mode and distribution of cracks of beams S-1 and S-2

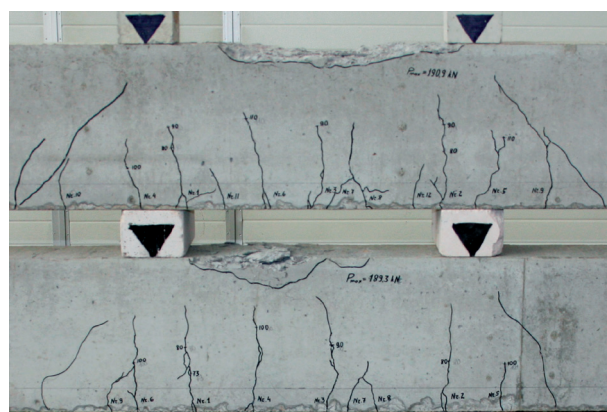

Fig. 7. Failure mode and distribution of cracks of prestressed beams SI-1 and SI-2

### Conclusions and Summary

From the performed experimental investigation and analysis of flexural behaviour of concrete beams with non-metallic reinforcement, the following conclusions have been made:

- From the standpoint of structural engineering, the effect of prestressing forces must be considered. According to this effect, the increase in the crack opening moment was observed. Disagreement of the cracking moment ratio to the ultimate moment is greater than 0.41, whereas for non-prestressed beams – 0.21.
- Because of the prestressing of GFRP reinforcement, high strength of GFRP rebar might be used more efficiently, when the reinforcement ratio is greater than the balanced reinforcement ratio.
- The disagreement between theoretical and experimental results is 5.89% when flexural strength is estimated using *fib* recommendations. The



most significant disagreement between theoretical and experimental results was received using the ACI code and amounted to 20.57%; 19.18% was received when the theoretical approach was based on the CAN/CSA code.

- It is certainly possible to forecast the failure mode of concrete members with non-metallic reinforcement taking into account flexural strength design methodology based on balanced reinforcement ratio. Experimental and forecasted failure mode of concrete beams coincided.

## References

- ACI 440.4R-04. 2011. *Prestressing concrete structures with FRP tendons*. American Concrete Institute, 13–16.
- Atutis, M.; Valivonis, J. 2010. Reinforcement characteristics of prestressed concrete beams with fiber-reinforced polymer (FRP) tendons, *Engineering Structures and Technologies* 2(2): 71–78. <http://dx.doi.org/10.3846/skt.2010.10>
- Atutis, M.; Valivonis, J. 2011. Anchorage characteristics of non-metallic reinforcement for concrete, *Engineering Structures and Technologies* 3(2): 72–78. <http://dx.doi.org/10.3846/skt.2011.09>
- Bank, L. 2006. *Composites for construction: structural design with FRP materials*. New Jersey: John Wiley & Sons, 143–150. <http://dx.doi.org/10.1002/9780470121429.ch5>
- Borosnyoi, A. 2002. *Serviceability of CFRP prestresses concrete beams*: PhD Thesis. Budapest University of Technology and Economics.
- Burke, Ch.; Dolan, W. 2001. Flexural design of prestressed concrete beams using FRP tendons, *PCI Journal* 46: 76–87.
- Canadian Standards Association. 2004. *Design and construction of building components with fiber reinforced polymers*. CAN/CSA-S806-02. Canada.
- CEB-FIP. 2007. *FRP reinforcement in RC structures*, FIB Bulletin No.40.
- Daugevičius, M.; Valivonis, J.; Beinaravičius, A.; Skuturna, T.; Budvytis, M. 2013. Experimental investigation of the load carrying capacity of eccentrically loaded reinforced concrete elements strengthened with CFRP, in *Procedia Engineering. 11th International Conference on Modern Building Materials, Structures and Techniques (MBMST)*, 2013. Amsterdam: Elsevier Science, 57: 232–237.
- Daugevičius, M.; Valivonis, J.; Marčiukaitis, G. 2012. Deflection analysis of reinforced concrete beams strengthened with carbon fibre reinforced polymer under long-term load action, *Journal of Zhejiang University-Science* 13(8): 571–583. <http://dx.doi.org/10.1631/jzus.A1100317>
- Daugevičius, M. 2010. *Influence of long-term load on the behaviour of reinforced concrete beams strengthened with carbon fibre composite*: PhD Thesis. Vilnius Gediminas Technical University. Vilnius: Technika. 150 p.
- Demers, M.; Popovic, A.; Neale, K. W.; Rizkalla, S.; Tadros, G. 2003. *FRP retrofit of the ring-beam of a nuclear reactor containment structure. In-field application of FRP reinforcement: case studies*. American Concrete Institute, 303–316.
- Gribniak, V.; Kaklauskas, G.; Torres, L.; Daniunas, A.; Timinskas, E.; Gudonis, E. 2013. Comparative analysis of deformations and tension – stiffening in concrete beams reinforced with GFRP or steel bars and fibers, *Composites Part B: Engineering* 50: 158–170. <http://dx.doi.org/10.1016/j.compositesb.2013.02.003>
- Kim, J. 2010. Flexural response of concrete beams prestressed with AFRP tendons: numerical investigation, *Journal of Composites for Construction* 14(6): 647–658. [http://dx.doi.org/10.1061/\(ASCE\)CC.1943-5614.0000128](http://dx.doi.org/10.1061/(ASCE)CC.1943-5614.0000128)
- Maruyama, T.; Honma, M.; Okamura, H. 1989. Experimental study on the diagonal tensile characteristics of various fiber reinforced plastic rods, *Transactions of the Japan Concrete Institute* 11: 193–198.
- LST EN 206-1: 2002. *Concrete – Part 1: Specification, performance, production and conformity*. Lithuanian Standards Board. 68 p.
- Skuturna, T. 2009. *Research of flexural reinforced concrete members strengthened with external carbon fibre*: PhD Thesis. Vilnius Gediminas Technical University. Vilnius: Technika. 138 p.

## LENKIAMŪJŲ ELEMENTŲ, ARMUOTŲ STIKLO PLUOŠTO ARMATŪRA, ELGSENOS STATMENAJAME PJŪVYJE EKSPERIMENTINIS TYRIMAS

E. Atutis, J. Valivonis, M. Atutis

**Santrauka.** Dėl dabartinės ekonominės situacijos vis labiau siekiama, kad konstrukcinis betonas būtų naudojamas kuo ilgiau. Ypač su sauga susijusioms gelžbetoninėms konstrukcijoms dažnai keliami reikalavimai, kad per eksploatacinį šių konstrukcijų laikotarpį pagrindinės betono savybės liktų nepakitusios, lyginant su projektinėmis vertėmis. Vis dėlto reikalavimai, keliami šių konstrukcijų eksploatavimui, yra unikalūs, tačiau nėra visiškai apibrėžti. Straipsnyje aprašomi sijų, armuotų stiklo pluošto armatūra, eksperimentiniai tyrimai, kuriuose buvo nagrinėjama šių sijų laikomoji galia statmenajame pjūvyje. Buvo bandomos sijos, armuotos išilgine iš anksto įtempta stiklo pluošto armatūra, ir sijos, armuotos neįtemptąja stiklo pluošto armatūra. Gautos statmenojo pjūvio laikomosios galios lyginamos su įvairiomis projektavimo normomis ir rekomendacijomis, analizuojama išankstinio įtempimo reikšmė sijų įlinkiui bei pleišetumui.

**Reikšminiai žodžiai:** stiklo pluošto armatūra, išankstinis įtempimas, statmenojo pjūvio laikomoji galia, eksperimentinis tyrimas.

**Edgaras ATUTIS.** BSc (Civil Engineering) at Vilnius Gediminas Technical University (VGTU). Research interests: mechanics of reinforced and prestressed concrete structures with non-metallic reinforcement, composite structures.

**Juozas VALIVONIS.** Doctor, Associate Professor at the Dept of Reinforced Concrete and Masonry Structures, Vilnius Gediminas Technical University (VGTU). Author of more than 55 publications. Research interests: theory of reinforced concrete behaviour, composite structures, reinforced concrete bridges.

**Mantas ATUTIS.** Design Solutions Manager at Visaginas Nuclear Power Plant Ltd. (VAE). MSc (Civil Engineering) at Vilnius Gediminas Technical University (VGTU). Research interests: special engineering structures, composite structures, finite element method.